

MIL75

_REV10

CEA DESIGN STUDIO



MIL75/MILO360

AISI 316/L STAINLESS STEEL

Miscelatore 2 fori con bocca di erogazione girevole

Two-hole mixer with swivelling spout



Portata aeratore 5 l/min / 1.3 gpm, risparmio idrico
Flow rate aerator 5 l/min / 1.3 gpm, water saving

MANUTENZIONE / MAINTENANCE

NON UTILIZZARE DO NOT USE		acido clorico e muriatico <i>cloric and muriatic acid</i>
		acido fluoridrico <i>hydrofluoric acid</i>
		ipoclorito di sodio <i>chlorine bleach</i>
UTILIZZARE TO USE		sapone a PH neutro <i>neutral PH soap</i>

Questi disegni sono proprietà di CEADESIGN SRL s.u. pertanto non potranno essere utilizzati e/o comunicati a terzi, anche in forma parziale, senza preventiva autorizzazione. CEADESIGN SRL s.u. si riserva il diritto di apportare modifiche ai disegni al fine di migliorare il prodotto.

CEADESIGN SRL s.u. has the property rights on these drawings, therefore they cannot be used and/or transferred to third party, even in partial form, without any prior authorization. Furthermore CEADESIGN SRL s.u. reserves the right to apply any change to these drawings in order to upgrade the product.

CEA

ceadesign.it

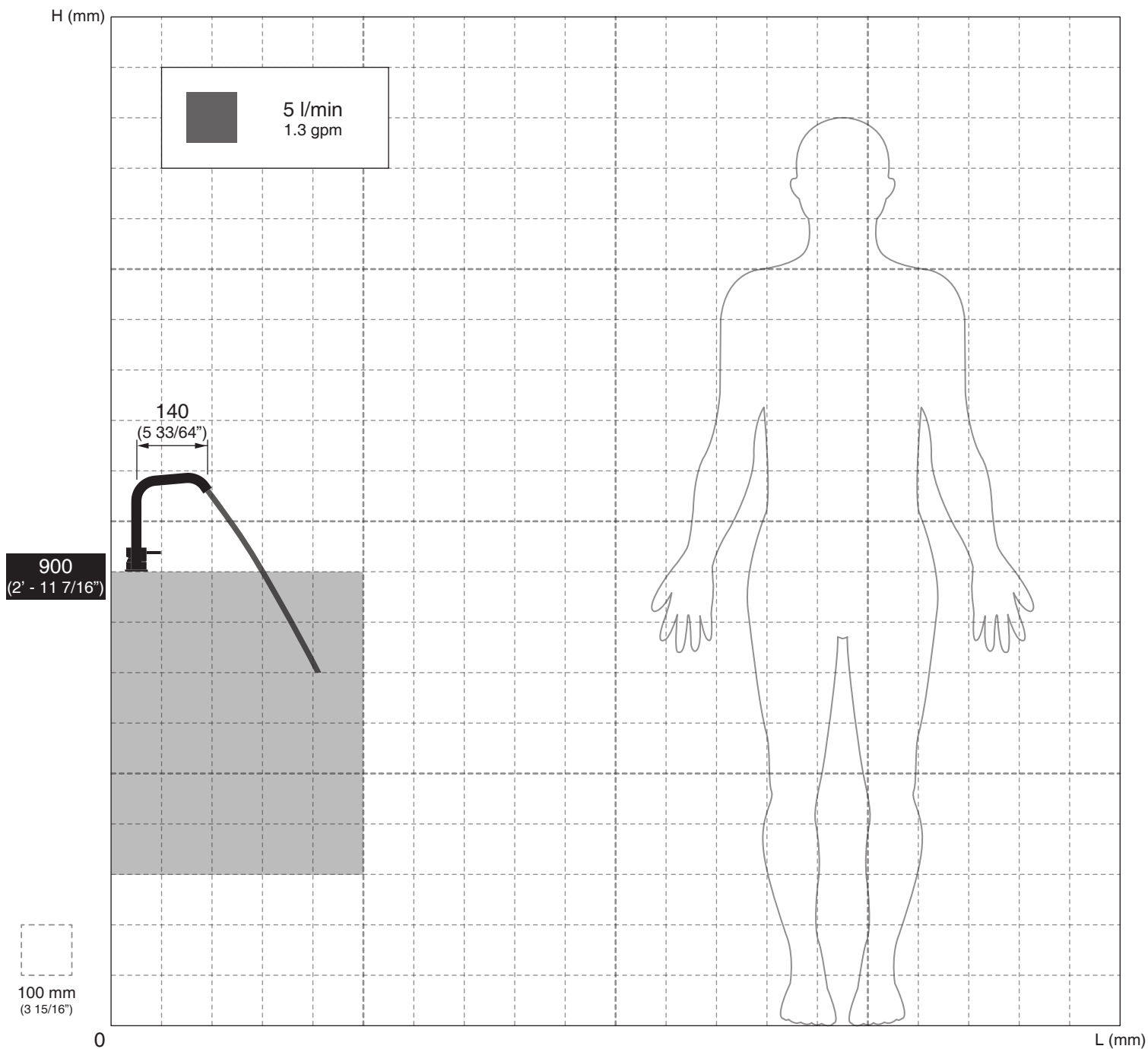

AVVERTENZE DI INSTALLAZIONE

L'altezza ottimale di installazione del prodotto si determina in base all'altezza dell'utente e del lavabo.
La rappresentazione ha valore puramente indicativo.

INSTALLATION WARNINGS

Each individual product has to be installed and adjusted to suit the user's and the washbasin height.
The representation is purely indicative.

INSTALLATIONS WARNUNG

Die optimale Anbringungshöhe der einzelnen Produkte ist abhängig von der Körpergröße der Benutzer und die Waschtisch.
Die Zeichnung ist rein indikativ.

ADVERTENCIAS DE INSTALACIÓN

La altura de colocación ideal de cada producto se determina conforme a la altura de la persona y del lavabo.
La representación es indicativa.

AVERTISSEMENTS D'INSTALLATION

La hauteur optimale de l'emplacement du produit est à déterminer selon la taille de la personne et la hauteur du lavabo.
La représentation est purement indicative.

AERATORE IN DOTAZIONE / AERATOR INCLUDED

 **Aeratore montato / Mounted aerator**
5 l/min / 1.3 gpm

AERATORI SU RICHIESTA / AERATORS ON DEMAND

 Conforme agli standard LEED / Compliant with LEED standards
1,9 l/min / 0,5 gpm

 Conforme agli standard LEED / Compliant with LEED standards
3,8 l/min / 1 gpm

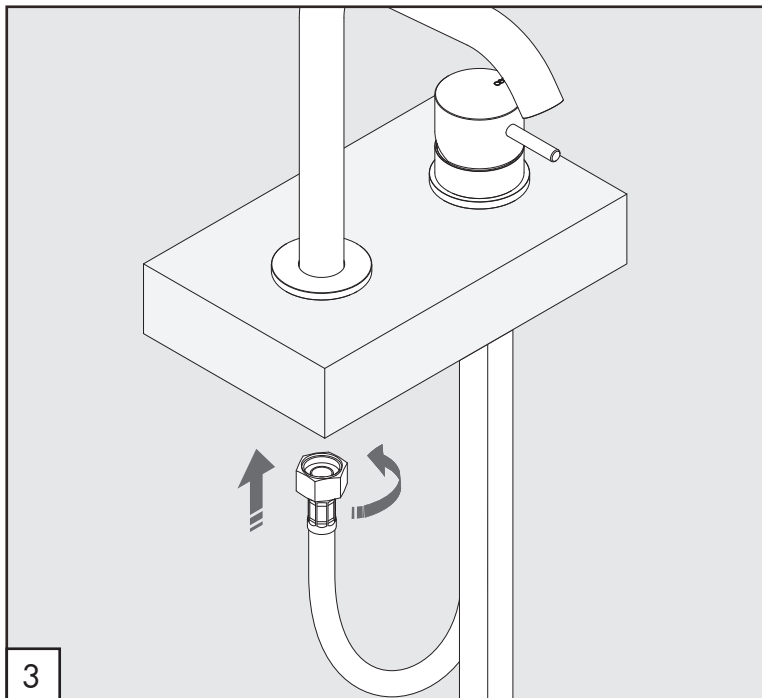
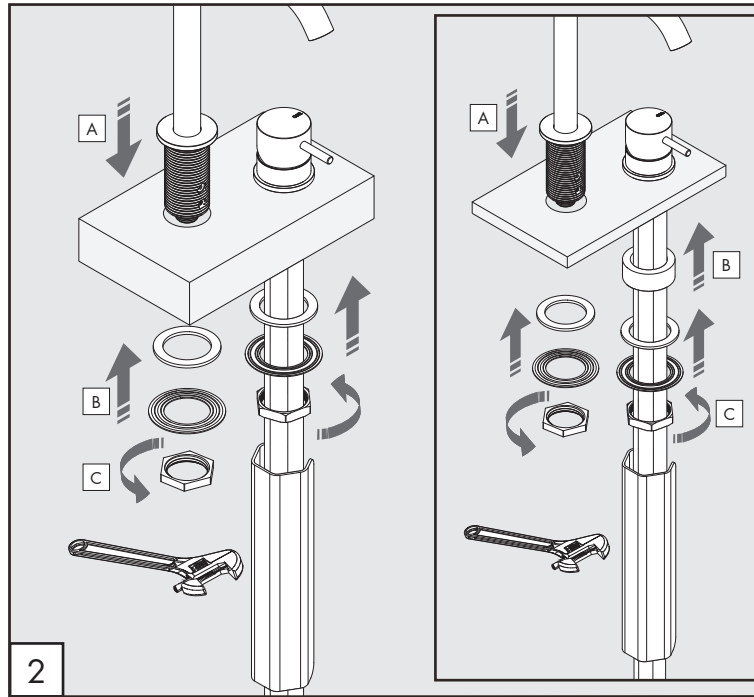
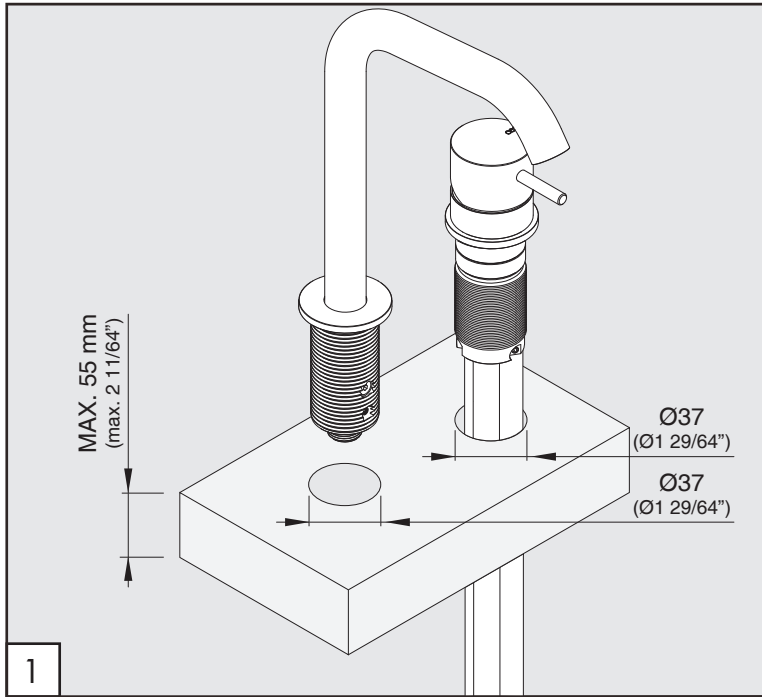

PULIZIA / CLEANING / SAUBEKEIT / LIMPIEZA / NETTOYAGE

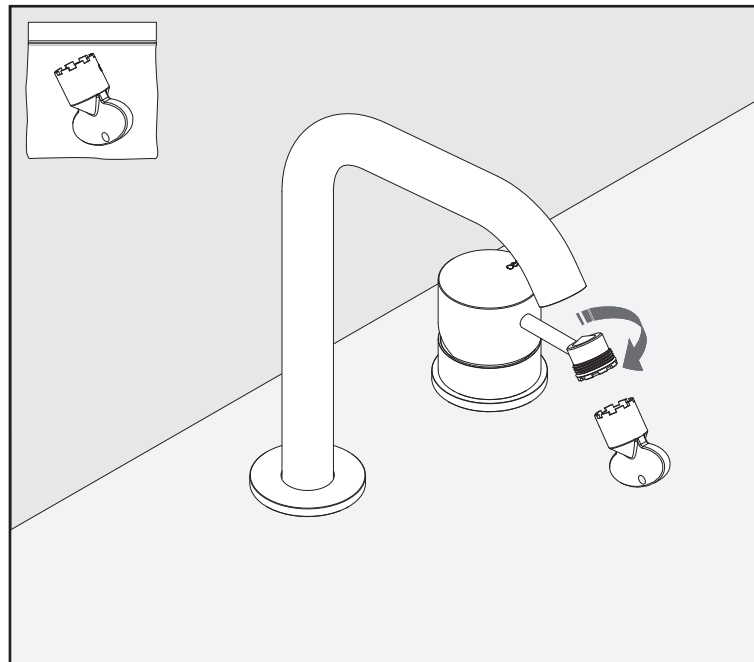

MIL75

_REV10

AVVERTENZE TECNICHE

Risciacquare bene le tubazioni prima del montaggio ed evitare sbalzi di pressione fra i raccordi d'acqua fredda e d'acqua calda. In caso di pressioni statiche superiori a 5 bar si raccomanda l'installazione di un riduttore di pressione per evitare danni alla cartuccia.

TECHNICAL WARNINGS

The pipes have to be rinsed thoroughly before installation. Avoid pressure differences between hot and cold water supply. Use of a pressure reducer when static pressure is higher than 5 bar to avoid damage of the cartridge.

TECHNISCHE WARNUNG

Spülen Sie die Leitungen vor dem Einbau und verhindern Sie Wasserdruckwechsel zwischen kalt und warm Wasserverbindungen. Wenn Wasserdruck größer als 5 bar ist, bitte reduzieren Sie den Systemdruck, um Beschädigung der Kartusche zu verhindern.

ADVERTENCIA TÉCNICA

Los tubos tienen que ser enjuagados a fondo antes de la instalación. Evitar grandes diferencias de presión entre las conexiones de agua caliente y fría. En caso de presión estática mayor de 5 bar, se recomienda el uso de un adaptador de presión para evitar daños en el cartucho.

ADVERTISSEMENTS TECHNIQUES

Rincer les tuyaux avant l'installation. Eviter des grandes différences de pression entre l'eau froide et chaude. En cas de pressions statique de plus de 5 bar, nous vous recommandons d'installer un réducteur de pression pour éviter des dommages à la cartouche.

TEMPERATURA DI ESERCIZIO / WORKING TEMPERATURE

🌡️ max. 70 °C
max. 158 °F

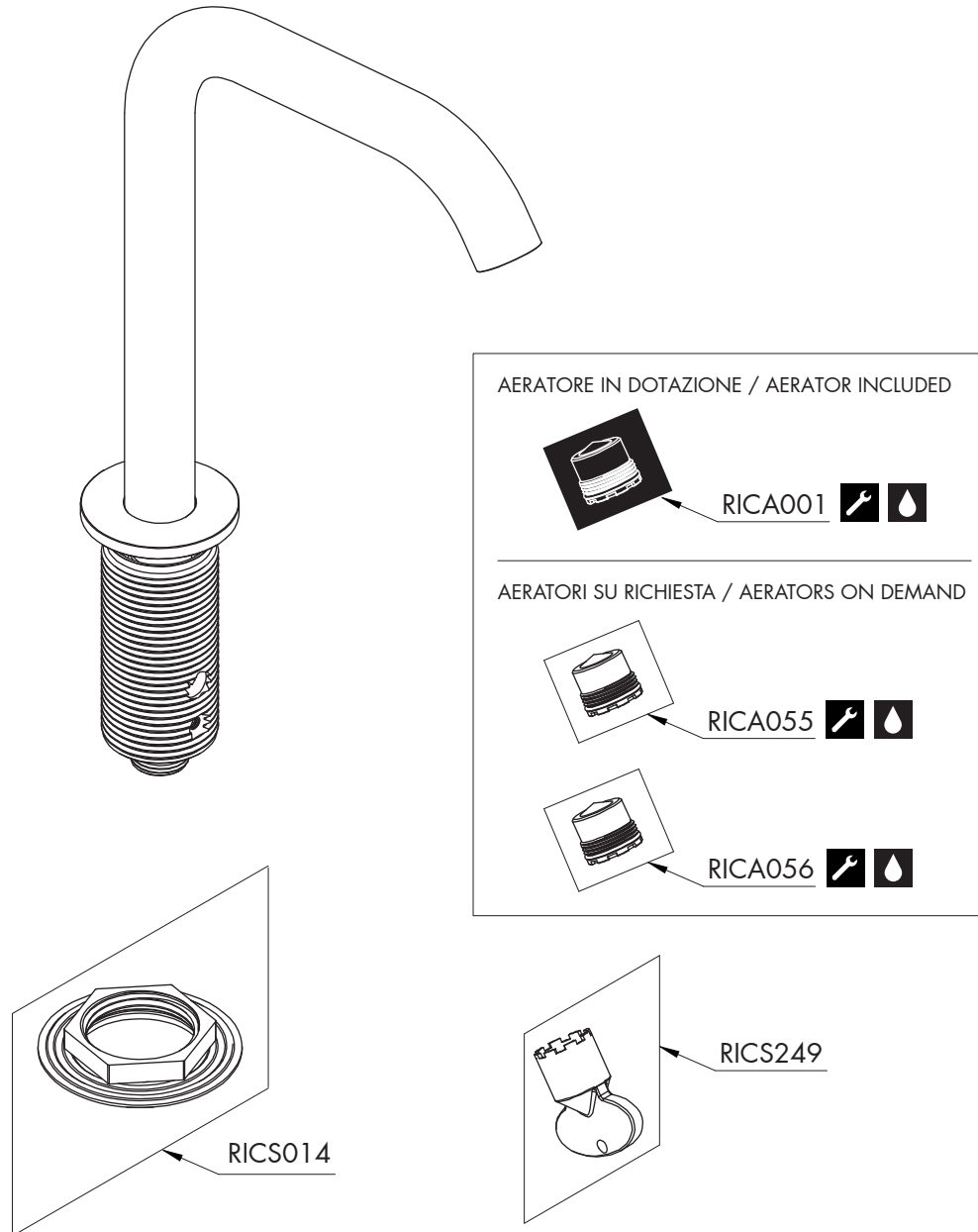

RICAMBI / SPARE PARTS

RICA001	Aeratore / Aerator	5 l/min / 1.3 gpm
RICS014	Kit di fissaggio / <i>Fixing kit</i>	
RICS249	Chiave aeratore / <i>Key for aerator</i>	

AERATORI SU RICHIESTA / AERATORS ON DEMAND

RICA055	Aeratore / <i>Aerator</i>	1,9 l/min / 0.5 gpm
RICA056	Aeratore / <i>Aerator</i>	3,8 l/min / 1 gpm

 Conservare gli strumenti inclusi nel prodotto e utilizzati per l'installazione perchè riutilizzabili per i ricambi.
Please, keep the tools included in the item pack and employed for its installation, to re-used them for the spare parts.

Die Werkzeuge, die Sie für die Installation des Produktes benutzt haben, bitte aufbewahren, da sie auch für die Installation der Ersatzteile benutzt werden können.

No tirar las herramientas incluidas en el producto y usadas durante la instalación puesto que se pueden reutilizar para los recambios.

Veuillez conserver les outils inclus dans la boîte du produit et employés pour son installation, parce que réutilisables pour les pièces de rechange.

LEGENDA / LEGEND

ICONE / ICONS

 Aeratore a risparmio idrico, utilizzabile per lavabo
Water saving aerator, suitable for wash-basin

 Utensile incluso nel ricambio
Tool included in spare part

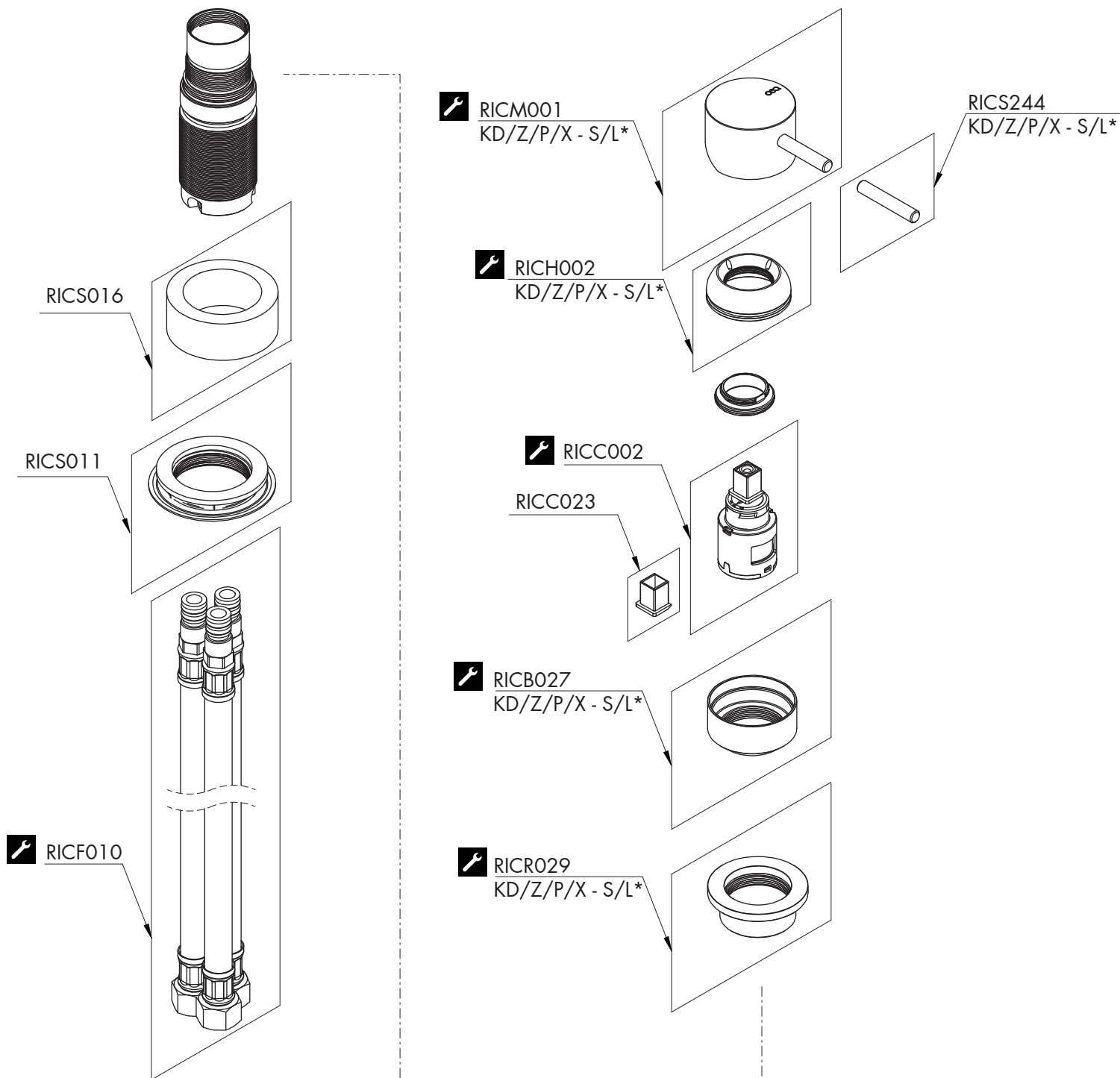

RICAMBI / SPARE PARTS

RICB027	Carter / Carter
RICC002	Cartuccia / Cartridge
RICC023	Adattatore cartuccia / Cartridge adapter
RICF010	Flessibile / Hose
RICH002	Ghiera / Sleeve
RICM001	Maniglia / Handle
RICR029	Rosetta / Rosette
RICS011	Kit di fissaggio / Fixing kit
RICS016	Anello di compensazione / Compensating ring
RICS244	Perno maniglia L.30 mm L.30 mm lever for handle

LEGENDA / LEGEND

ICONE / ICONS

 Utensile incluso nel ricambio
Tool included in spare part

FINITURE / FINISHES

*S finitura satinata / satin finish
L finitura lucidata / polished finish

FINITURE SPECIALI / SPECIAL FINISHES

KD black diamond
Z bronzo / bronze
P rame / copper
X light gold