

PTR03

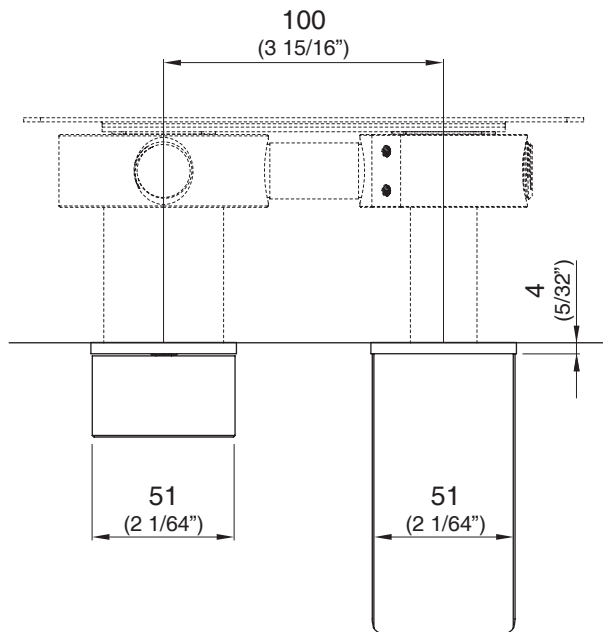

# BAR17

\_ REV1.5

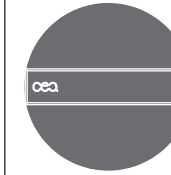

## BAR17/BAR

AISI 316L STAINLESS STEEL

Miscelatore progressivo a parete con bocca di erogazione

*Wall mounted progressive mixer with spout*

DESIGN  
NATALINO MALASORTI



Intertek



Portata aeratore 5,7 l/min / 1.5 gpm, risparmio idrico  
*Flow rate aerator 5,7 l/min / 1.5 gpm, water saving*



Possibilità di installazione a 90°  
*Installation possibility at 90°*



Possibilità di installazione a 180°  
*Installation possibility at 180°*



Prodotto che necessita di parte incasso  
*Product that needs built-in part*



Staffa ausiliaria per cartongesso / fibrogesso  
*Auxiliary bracket for plasterboard / fiber-board structures*

### MANUTENZIONE / MAINTENANCE

NON UTILIZZARE DO NOT USE		acido clorico e muriatico <i>chloric and muriatic acid</i>
		acido fluoridrico <i>hydrofluoric acid</i>
		ipoclorito di sodio <i>chlorine bleach</i>
UTILIZZARE TO USE		detergente a pH neutro <i>neutral pH detergent</i>

Questi disegni sono proprietà di CEADDESIGN SRL s.u. pertanto non potranno essere utilizzati e/o comunicati a terzi, anche in forma parziale, senza preventiva autorizzazione. CEADDESIGN SRL s.u. si riserva il diritto di apportare modifiche ai disegni al fine di migliorare il prodotto.

*CEADDESIGN SRL s.u. has the property rights on these drawings, therefore they cannot be used and/or transferred to third party, even in partial form, without any prior authorization. Furthermore CEADDESIGN SRL s.u. reserves the right to apply any change to these drawings in order to upgrade the product.*

# CEA

ceadesign.it

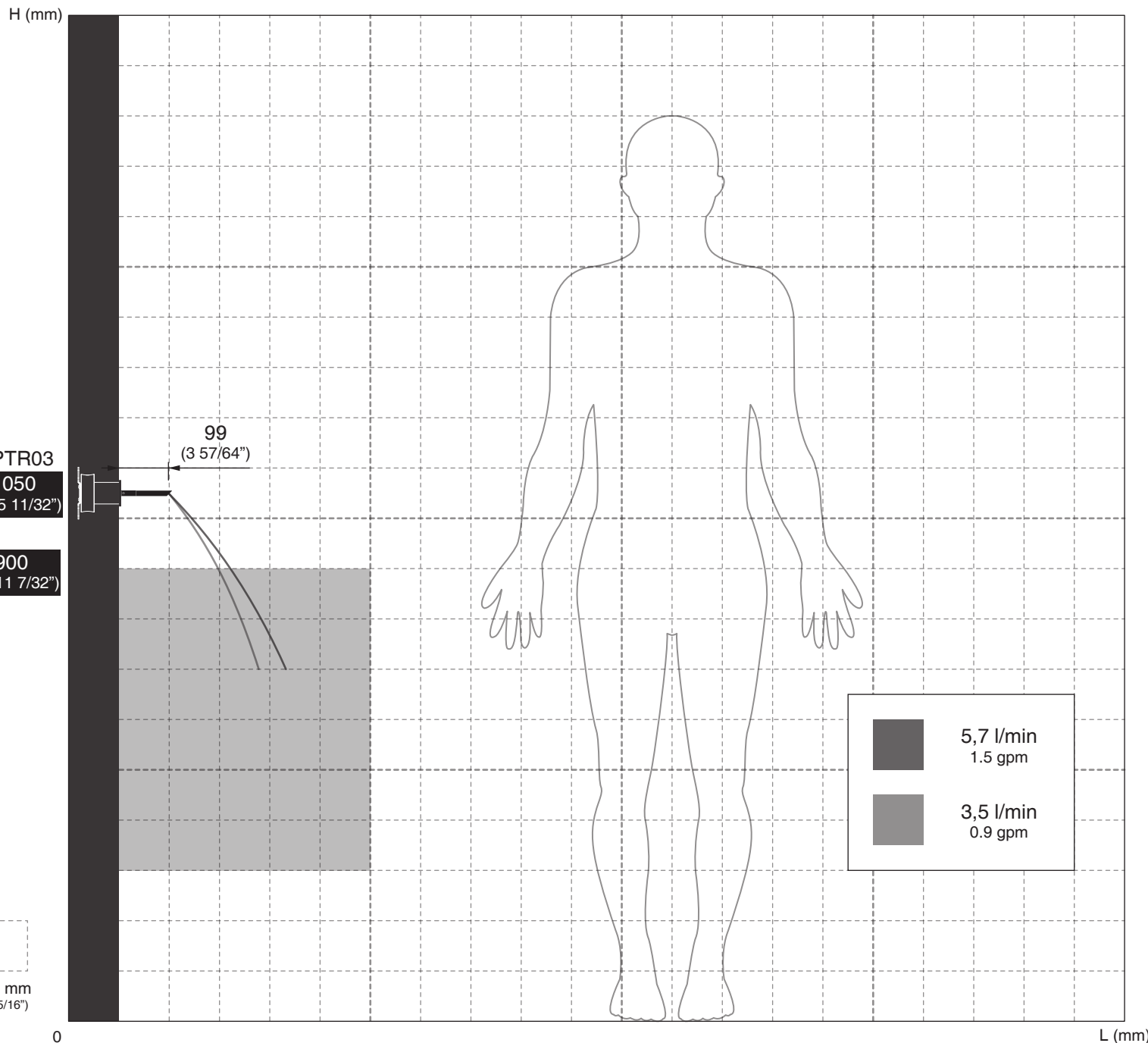

AVVERTENZE DI INSTALLAZIONE

L'altezza ottimale di installazione del prodotto si determina in base all'altezza dell'utente e del lavabo.  
La rappresentazione ha valore puramente indicativo.

INSTALLATION WARNINGS

Each individual product has to be installed and adjusted to suit the user's and the washbasin height.  
The representation is purely indicative.

INSTALLATIONS WARNING

Die optimale Anbringungshöhe der einzelnen Produkte ist abhängig von der Körpergröße der Benutzer und die Waschtisch.  
Die Zeichnung ist rein indikativ.

ADVERTENCIAS DE INSTALACIÓN

La altura de colocación ideal de cada producto se determina conforme a la altura de la persona y del lavabo.  
La representación es indicativa.

AVERTISSEMENTS D'INSTALLATION

La hauteur optimale de l'emplacement du produit est à déterminer selon la taille de la personne et la hauteur du lavabo.  
La représentation est purement indicative.

AERATORI IN DOTAZIONE / AERATORS INCLUDED

**Aeratore montato / Mounted aerator**  
5,7 l/min / 1.5 gpm

**Riduttore di portata / Flow regulator**  
3,5 l/min / 0.9 gpm

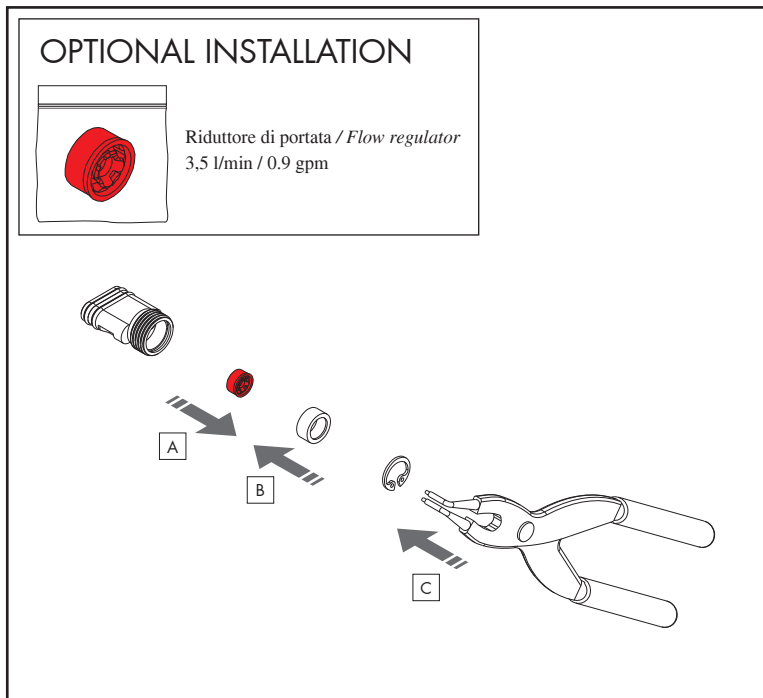
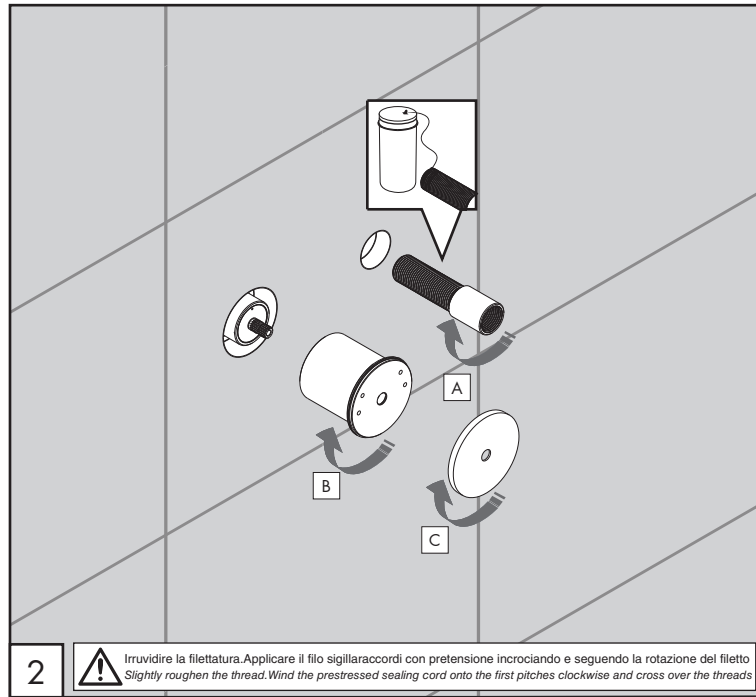
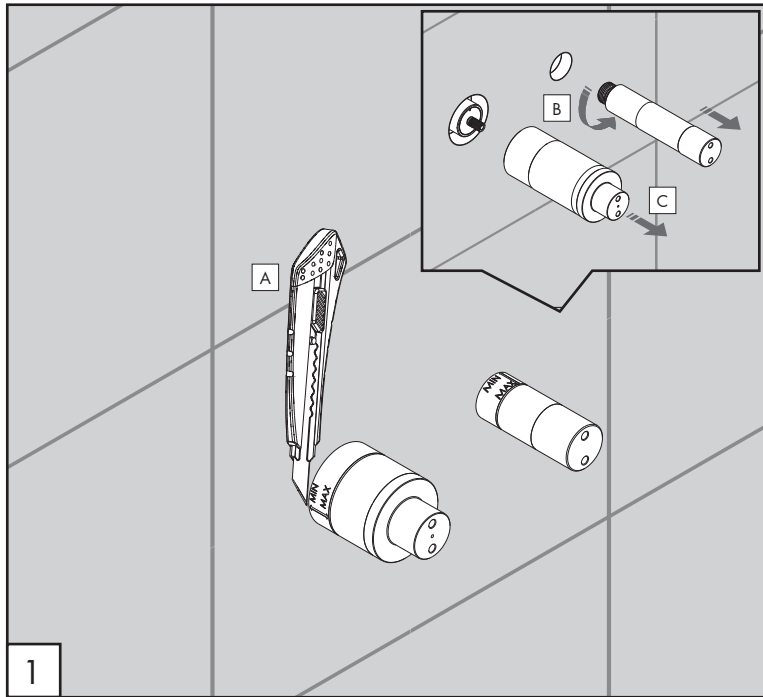

## AVVERTENZE TECNICHE

Risciacquare bene le tubazioni prima del montaggio ed evitare sbalzi di pressione fra i raccordi d'acqua fredda e d'acqua calda. In caso di pressioni statiche superiori a 5 bar si raccomanda l'installazione di un riduttore di pressione per evitare danni alla cartuccia.

## TECHNICAL WARNINGS

The pipes have to be rinsed thoroughly before installation. Avoid pressure differences between hot and cold water supply. Use of a pressure reducer when static pressure is higher than 5 bar to avoid damage of the cartridge.

## TECHNISCHE WARNUNG

Spülen Sie die Leitungen vor dem Einbau und verhindern Sie Wasserdruckwechsel zwischen kalt und warm Wasserverbindungen. Wenn Wasserdruck größer als 5 bar ist, bitte reduzieren Sie den Systemdruck, um Beschädigung der Kartusche zu verhindern.

## ADVERTENCIA TÉCNICA

Los tubos tienen que ser enjuagados a fondo antes de la instalación. Evitar grandes diferencias de presión entre las conexiones de agua caliente y fría. En caso de presión estática mayor de 5 bar, se recomienda el uso de un adaptador de presión para evitar daños en el cartucho.

## ADVERTISSEMENTS TECHNIQUES

Rincer les tuyaux avant l'installation. Eviter des grandes différences de pression entre l'eau froide et chaude. En cas de pressions statique de plus de 5 bar, nous vous recommandons d'installer un réducteur de pression pour éviter des dommages à la cartouche.

## TEMPERATURA DI ESERCIZIO / WORKING TEMPERATURE

max. 70 °C  
max. 158 °F

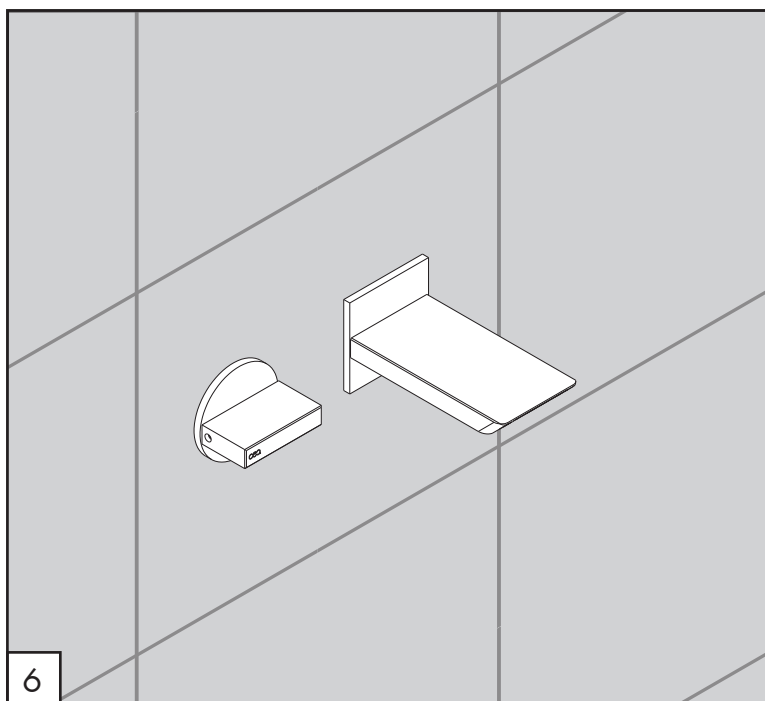
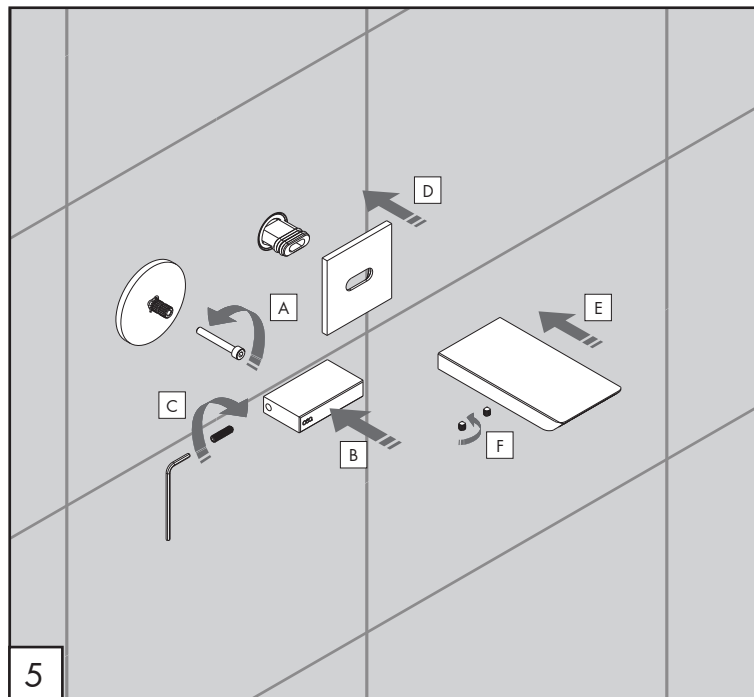
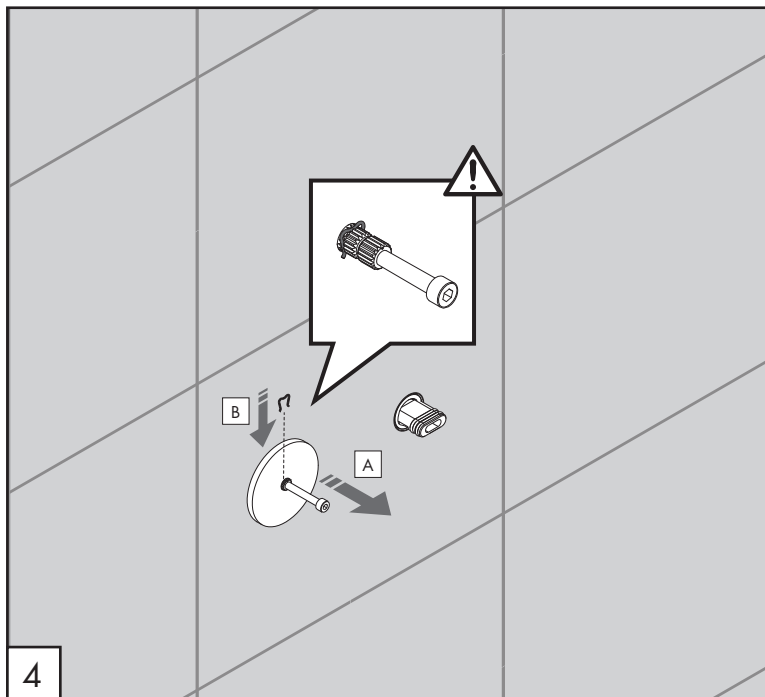

## PULIZIA / CLEANING / SAUBEKEIT / LIMPIEZA / NETTOYAGE

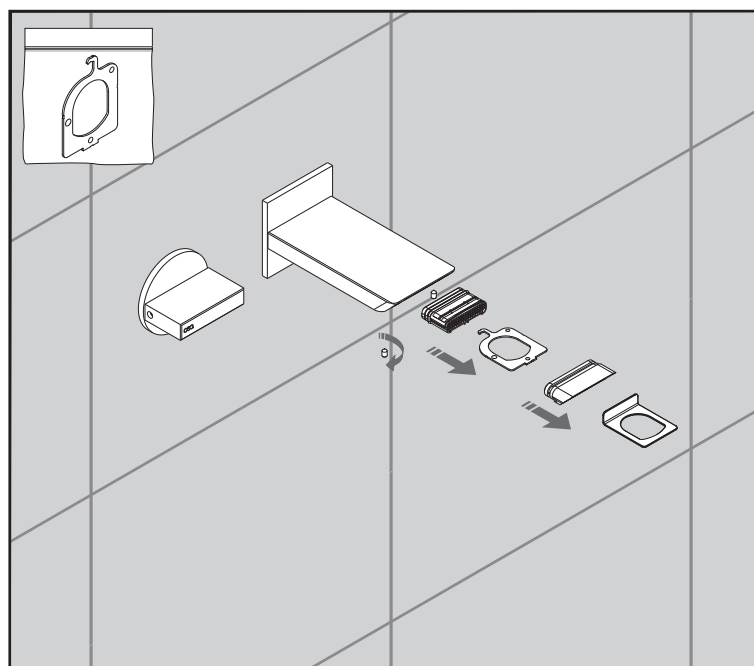

**!** Conservare gli strumenti inclusi nel prodotto e utilizzati per l'installazione perchè riutilizzabili per i ricambi.  
 Please, keep the tools included in the item pack and employed for its installation, to re-used them for the spare parts.  
 Die Werkzeuge, die Sie für die Installation des Produktes benutzt haben, bitte aufbewahren, da sie auch für die Installation der Ersatzteile benutzt werden können.  
 No tirar las herramientas incluidas en el producto y usadas durante la instalación puesto que se pueden reutilizar para los recambios.  
 Veuillez conserver les outils inclus dans la boîte du produit et employés pour son installation, parce que réutilisables pour les pièces de rechange.

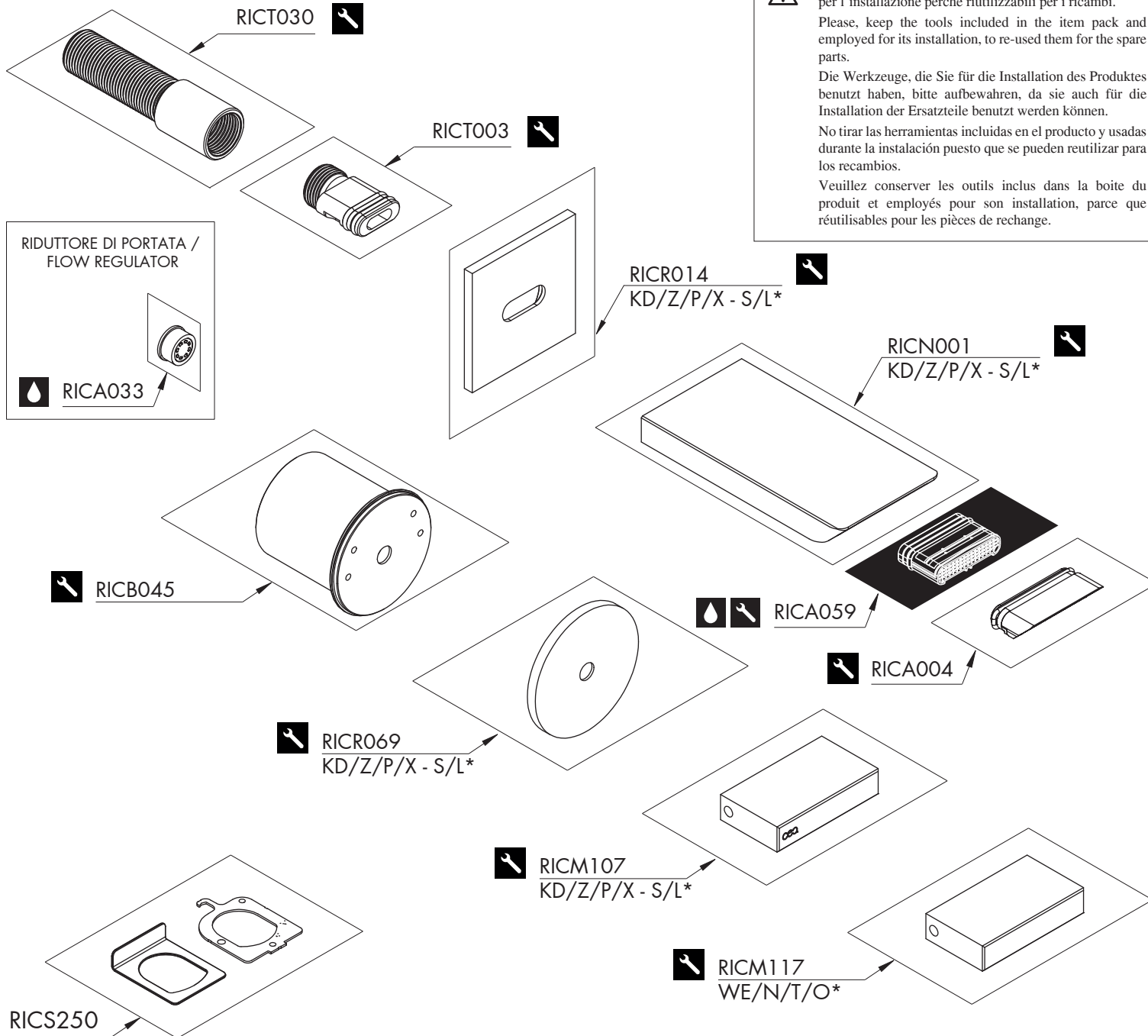

## RICAMBI / SPARE PARTS

RICA004	Inserto bocca di erogazione / <i>Spout insert</i>	
RICA033	Riduttore di portata / <i>Flow regulator</i>	3,5 l/min / 0.9 gpm
<b>RICA059</b>	<b>Aeratore / Aerator</b>	<b>5,7 l/min / 1.5 gpm</b>
RICB045	Carter / <i>Carter</i>	
RICM107	Maniglia / <i>Handle</i>	
RICM117	Maniglia / <i>Handle</i>	
RICN001	Bocca di erogazione / <i>Spout</i>	
RICR014	Rosetta / <i>Rosette</i>	
RICR069	Rosetta / <i>Rosette</i>	
RICT003	Raccordo / <i>Fitting</i>	
RICT030	Raccordo / <i>Fitting</i>	
RICS250	Chiave aeratore / <i>Key for aerator</i>	

## LEGENDA / LEGEND

### ICONE / ICONS

- Aeratore a risparmio idrico, utilizzabile per lavabo / *Water saving aerator, suitable for wash-basin*
- Utensile incluso nel ricambio / *Tool included in spare part*

### FINITURE / FINISHES

- \*S finitura satinata / *satin finish*
- L finitura lucidata / *polished finish*

### FINITURE SPECIALI / SPECIAL FINISHES

- KD black diamond
- Z bronzo / *bronze*
- P rame / *copper*
- X light gold

### ESSENZE LEGNO / WOOD ESSENCES

- \*WE wengè / *wenge*
- N noce americano / *american walnut*
- T teak birmano / *burma teak*
- O rovere / *oak*